

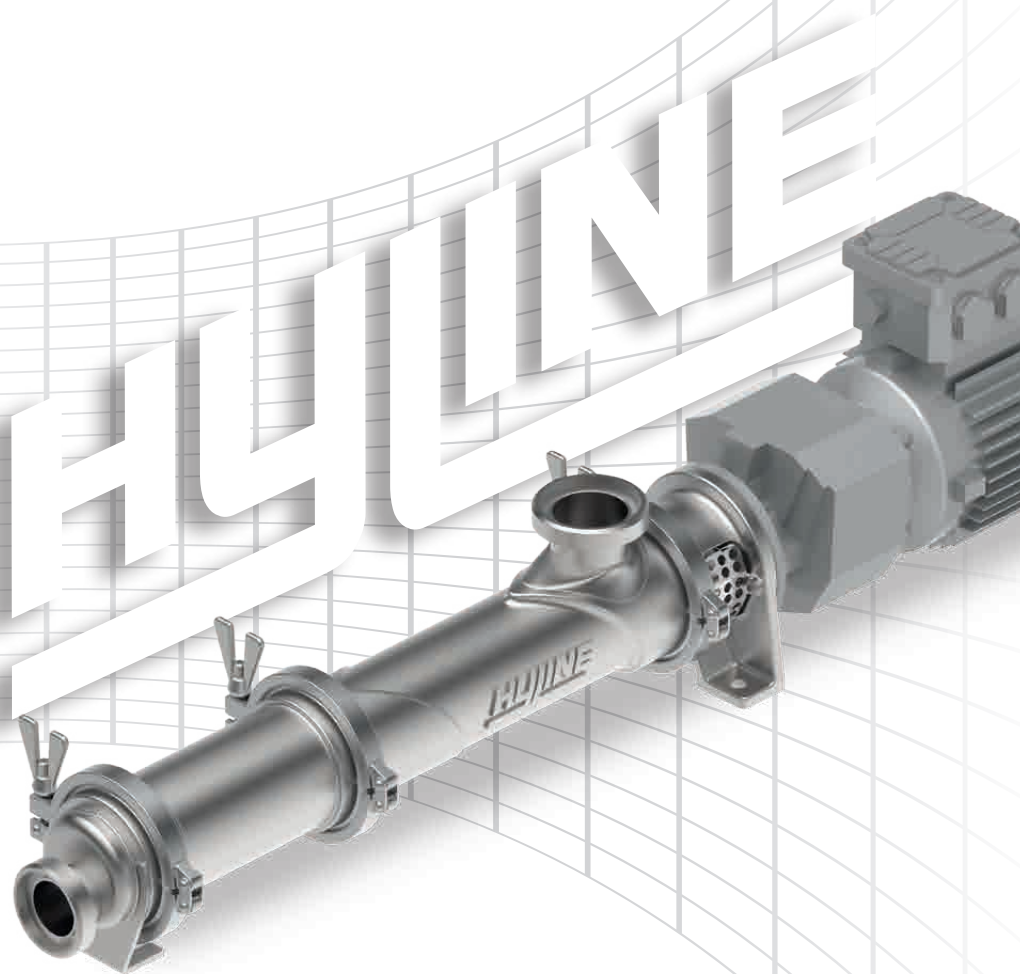

Hygienic Progressing Cavity Pump **WANGEN HYLINE**



For hygienic conveying and dosing in
the food & beverage-, cosmetics- and
pharmaceutical industry



WANGEN HYLINE

Features and characteristics

The WANGEN HYLINE is designed by WANGEN PUMPEN to ensure optimal performance and operational reliability.

The hygienic-related design of the WANGEN HYLINE was implemented according to the strict GMP (Good Manufacturing Practice) Directives, which are assuming an increasingly important role in the food, pharmaceutical and cosmetics sectors. For this purpose, as is usual with WANGEN PUMPEN, special value is placed on quality - and this means on lifetime duration.

Hygienic Highlight: The flexible and maintenance-free joint is coated with elastomer. A constant shaft diameter construction design prevents sedimentation of the media to be pumped.

In order to enable the conveyance of a wide spectrum of media, a large selection of single-acting and double-acting shaft seals are available for the HYLINE, such as the encapsulated seals, single acting seal with elastomer bellows or gland packing.

The intelligent design of this hygienic pump requires no additional seals in the product chamber. Pump disassembly is easily carried out by removing all pump component connections outside the product chamber.

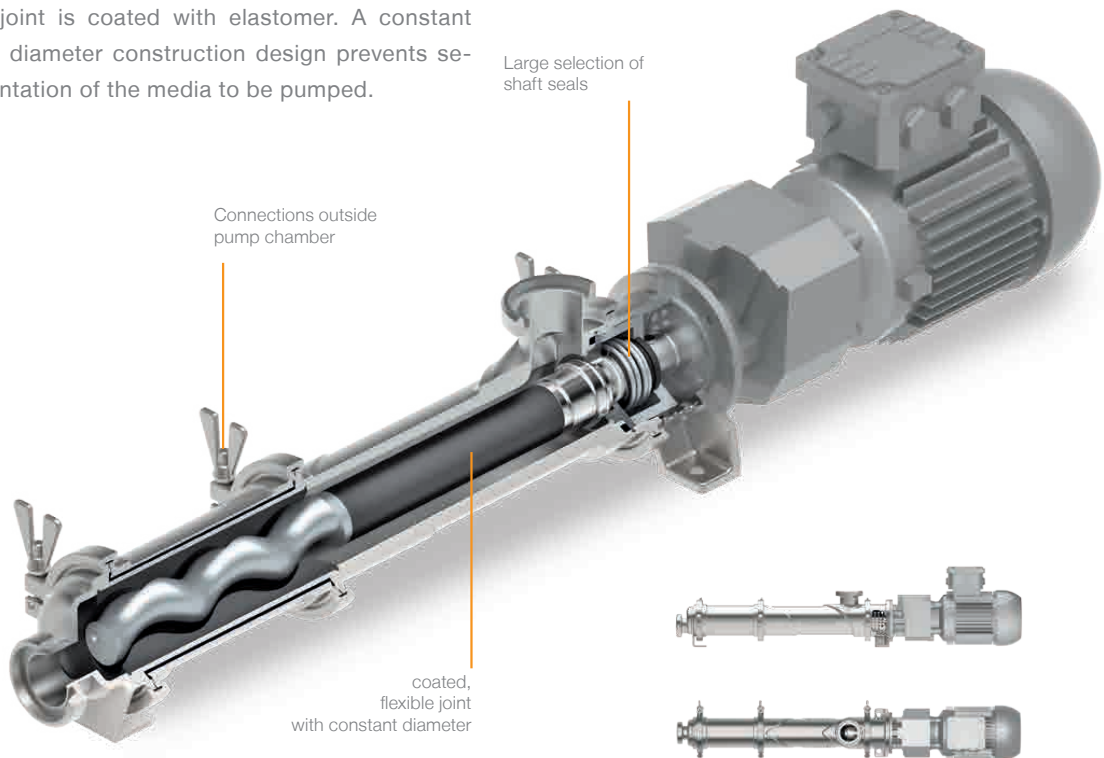

Technical data and properties

Performance data WANGEN HYLINE

| Pump size | Maximum completely free passage (mm) | Flowrate (m³/h) | Maximum differential pressure (bar) |
|-----------|--------------------------------------|-----------------|-------------------------------------|
| 20 | 26 | 0,02 up to 7 | 20 |

Characteristics:

- Designed according to the strict directives of EHEDG, 3A and GMP
- Low dead space design for optimal cleaning capability
- Temperature -30 °C - 140 °C
- Viscosity up to 100.000 mPa·s

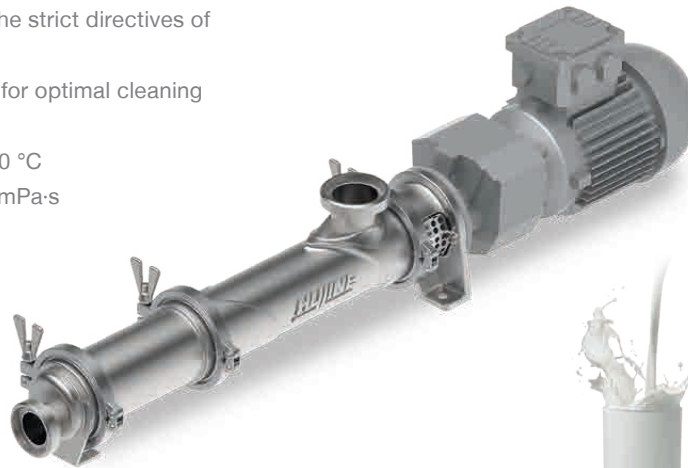

Conveying media:

- Dairy products, such as butter, margarine, milk, yoghurt, processed cheese
- Drinks, such as fruit juice, beer
- Confectionery, such as chocolate, liquid sugar, marzipan, waffle mass, fondant mass or glazes
- Mustard, ketchup, mayonnaise, soy sauce or tomato pureé
- Pastes
- Honey, caramel or gelatine
- Ice cream, jam
- Pet food
- Cosmetics, such as shampoo, face cream or soap
- Pharmaceutical products



FOR A SUCCESSFUL PARTNERSHIP

Rototec AG

Luzernstrasse 224c
3078 Richigen

+41 31 838 40 00
info@rototec.ch

www.rototec.ch



ENVIRONMENTAL INDUSTRY

Effluent, recycling,
hazardous waste processing, waste-to-energy
plants, biogas, sewerage systems, agriculture



DESIGNERS

Plant engineering, machine construction,
process engineers,
Engineers



MANUFACTURING INDUSTRY

Paper, cardboard, cellulose, ceramics,
coatings, electroplating, plastics,
wood products, glass, tiles



CHEMICAL INDUSTRY

Adhesives, paints,
Chemicals, bitumen, latex,
Oils and fats

THE RIGHT PUMP FOR YOUR SECTOR



FOODSTUFFS

Bakery and dairy products, drinks,
delicatessen products, confectionery, chocolate,
sugar, meat, fruit and vegetables



WATER

Sanitary items / infrastructure, fire brigade,
flood control, shipping



PHARMACEUTICALS & COSMETICS

Creams, ointments, feedstocks,
Animal health



CONSTRUCTION INDUSTRY

Concrete manufacturing, insulation materials,
Cement manufacturing, geothermal applications,
tunnel construction,
gravel quarries, cement products